

UDC 621.548

O. Dauylbaev, B.T. Elubaeva, R.K. Manatbayev*, L.A. Sadikova, A.T. Tulegenova
Physical-Technical Department of al-Farabi Kazakh National University

Theoretical basis of natural ventilation inside darrieus

Abstract

Windmills belong to the most advanced systems, the so-called alternative energy. For example, offshore wind farms today are an important source of renewable energy in many countries, having access to the Baltic and North seas.

However, in some regions, especially where the climate is characterized by severe winters, operating manager faced with a very serious problem - the formation of ice on the propeller blades. "At some point the ice with the blade breaks and flies away to a distance of two hundred or three hundred meters, often it is a hefty piece of ice weighing pounds, or even two. Of course, such a bomb might kill. "And these problems are not limited. In the winter for 5 months, employees of Swedish firms were round the clock monitoring of one of the Swedish wind turbines near the city of Herne è Sand, measuring wind speed, the thickness of ice on the blades and the performance of wind turbines. It turned out that even a slight crust of ice greatly reduces the efficiency of installation, since the sharp deterioration in the aerodynamic characteristics of blades. As soon as the thickness exceeds one millimeter ldi begin losses. As a result of this wind turbine developed by 15 per cent less electricity. Even if these losses are "scatter" for the entire year, you still get more than 5 percent - a very a significant number. "

The problem of an icing relevant for almost all wind turbines: their performance drops significantly in the winter. Not only that, due to the freezing of supercooled rain or sleet worse aerodynamics of the blades, so wind turbines and then have to turn off altogether if the thickness of the ice layer exceeds a critical value. The same situation is observed in Finland and in northern Germany, and Switzerland and Russia.

In this work we are considered natural air convection by influence carioles force in direct blade internal hole of Darrieus wind turbine and thermo saving of carousel type wind turbine construction version.

Key words: Glaze effects, natural internal ventilation, Darrieus wind, external shaft, vertical ring channel, household heating system.

Introduction

The way is offered by thermal protection of external surfaces working the wind-power unit from drifts by snow during winter time at the expense of the organization of natural ventilation of air and of its internal cavities, corresponding constructive decisions for realization.

The way concerns an infrastructure of windpower engineering – to maintenance of stable work wind power installations rotary type in severe environmental conditions by use of natural ventilation of warm air in the rotating elements of wind turbine (WT), arise owing to centrifugal forces.

Prototype of a way offered by us is wind power plant Darrieus, used for transformation of wind power to an electricity [1].

Main part

The central, Northern and East areas of Kazakhstan have sharply continental climate with severe winters and

glaze effects. During the periods of the vital need in thermal and electric energy, WT can be put out of action owing to drifts by a sleet with the subsequent sharp fall of temperature of air and formation of a heavy ice cover on them.

There is a big danger that there will be the same with them, as with a transmission line shown on fig. 1. One of possible ways of protection of external surfaces working wind turbine Darrieus from sticking of a sleet is the heating the warm air proceeding through internal channels of the device.

There are data that VEU cover with a waterproof paint that, probably, protects from a continuous covering rain drops, but hardly can save from sedimentation (sticking) of damp snowflakes on a cold surface of details WT at minus temperature of environment. Therefore thermal protection is more radical means. And, at strong frosts it besides rescues bearings from freezing.

In application to WT any design the way offered by us has no analogues, if not as an analog the household heating system.

The circuit diagrammed of realization the way of thermal protection for wind turbines carousel type on example H - a rotor is shown on fig. 2.

*Corresponding author e-mail: rustem1977@mail.ru



Figure 1- Condition of a transmission line after a snow storm in Pavlodar oblast

At turbine rotation there is a centrifugal force $|\vec{F}| = \rho\omega^2 l_1$ (where ρ - air condensation, ω - angular speed of rotation of the turbine, l_1 - length of a move), there are apertures in atmosphere on which ends directed along mach towards working blades.

Movements and working blades represent the channels formed symmetric wind by NASA – 0021 profile. Under the influence of force \vec{F} air inside the mach will move to working blades of the turbine, to be thrown into the atmosphere, and simultaneously causing air suction on the vertical ring channel, formed between the central rack WT and external shaft of rotation. Therefore, there is a natural internal ventilation of the device at a circular motion of the moves, caused by action of centrifugal forces

$$\frac{dP}{dl_1} = \rho\omega^2 l_1 \tag{1}$$

From here it is easy to calculate the pressure difference on the ends of mach

$$\Delta P_1 = P_1 - P_2 = \rho\omega^2 \frac{l_1^2}{2} \tag{2}$$

The current of a viscous liquid in the channel of mach tests resistance of a friction

$$\frac{dP}{dl_1} = \frac{\lambda_1 \rho u_1^2}{2d_1} \quad \text{or} \quad P_1 - P_2 = \frac{\lambda_1 l_1 \rho u_1^2}{2d_1} \tag{3}$$

where u_1, d_1, λ_1 – accordingly to the middle speed, to diameter equivalent and factor of hydraulic resistance of the Mach channel.

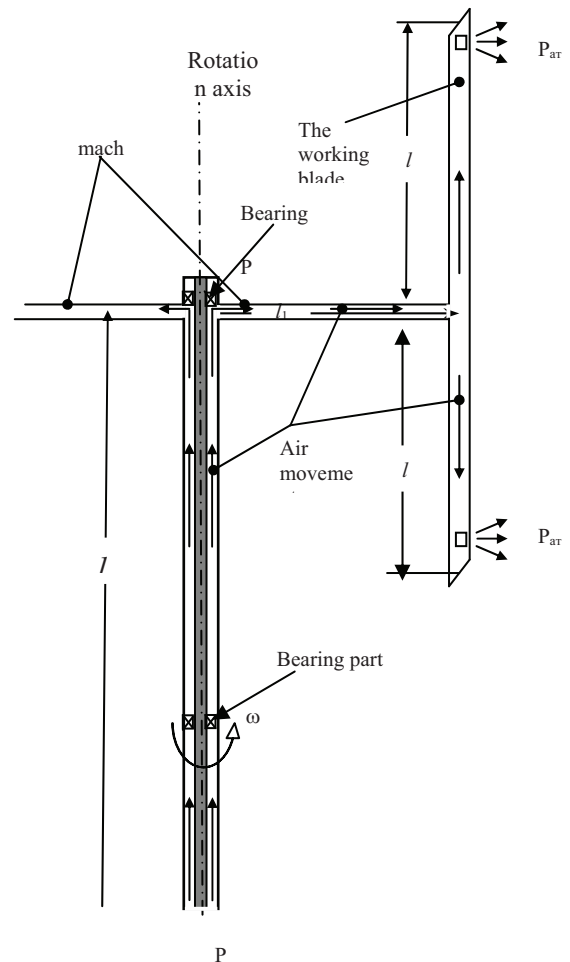

Figure 2 - Natural ventilation of air, as the result of working in centrifugal forces

Then every second work of centrifugal forces on movement of air weight along the Mach, less work on overcoming of forces of viscous resistance registers can be written as:

$$A_1 = 2 \left(\frac{\rho\omega^2 l_1^2}{2} - \frac{\lambda_1 l_1 \rho u_1^2}{2d_1} \right) * u_1, \tag{4}$$

where number 2 summarizes work of both moves. Natural ventilation wind turbine is possible, if A_1 will be more or equal to the sum of works on overcoming resistance of a friction in the ring channel in length l_0 and in the working blade– l_2

$$A_0 = \frac{\lambda_0 l_0 \rho u_0^3}{2d_0}, \tag{5}$$

which is λ_0, d_0, u_0 – given parameters for ring channel (cm. [2]), and also in blades

$$A_2 = \frac{\lambda_2 l_2 \rho u_2^3}{d_2} \tag{6}$$

which is λ_2, u_2, d_2 – accordingly parameters of the working blade (symbols in the formula (3))

The formula (6) was taking into account that $d_1=d_2$ and air will move on four channels in length l , with speeds of $u_1/2$. Therefore the necessary condition of definition of angular speed of rotation of the turbine ω ,

which is providing natural ventilation of elements of the turbine, is $A_1 \geq A_0 + A_2$.

Substituting expressions (4), (5) and (6), after simple transformations we will receive:

$$\omega \geq \sqrt{\frac{\lambda_0 l_0 u_0^3}{2d_0 l_1^2 u_1} + \frac{u_1^2 (\lambda_2 + 8\lambda_1)}{8d_1 l_1}} \quad (7)$$

As an example we will consider Darrieus wind turbine with the direct blades capacity of 6-7 kw at mid-annual speed of a wind in 6-7 km/s.

As it is known, the maximum value of operating ratio of wind power $\xi=0,45$ is between size of rapidity of the

$$\text{turbine } \chi = \frac{\omega l_1}{U} = 4 - 5$$

Capacity of wind turbine is defined by this formula

$$N_g = \xi S \rho \frac{U^3}{2}, \quad (8)$$

which is U – is the wind speed, S - surface. In $U=7$ m/s specific capacity of a wind on $1m^2$ $N_g = 221,2 Bm$.

From this wind turbine capacity can remove from each square meter of each sections in the turbine no more 100 W and 7 kW turbine must have $S = 70 M^2$, i.e. there are more hardly 8 meters working blades and length of moves more than 4 m. Mach should be located at height (l_0) not less than 7 m. For simplicity we will accept $S = 64 m^2$ i.e. $8m \times 8m$. Then the chord of blades and mach will be $b=1m$. At profile NASA – 0021 relation of perimeter of wing Φ to a chord b is approximately equal 2,1. In this case the area of their section $f_1=0.14 m^2$, $d_1=0,28$ m. If to accept $u_1=2$ m/s, that Reynolds's number in a cavity l_1 mach $Re=37333$.

In the formula (7) unknown could be a factor of hydraulic resistance of channels with NASA – 0021 form, applied as moves and working blades. In this connection special experiment with a purge of the channel having the form wings of NASA – 0021 profile [3] has been put. The factor of its hydraulic resistance is established

$$\lambda = 4,62 Re^{-0,488}$$

where Reynolds's Re number is defined on middle speeds of air in the channel u_1 and to its equivalent diameter $d_5=4f/\Phi$ (f - the area of section of the channel, Φ -its perimeter).

In l_2 cavities $Re_2=18567$ and $\lambda_2=0,034$. The expense of air in each mach $Q/2=0,28 m^3/s$ or $Q=0,56 m^3/s$.

As we mentioned before $l_0=7$ m. Diameter of the central rack we will put the equal 0,15 m in 15 m length. Then it is possible to use bearings with inside diameter $d=150$ mm and outside $D=270$ mm. Diameter equivalent of a ring cavity $d_0=0,12$ m, and the area of its section $0,188 m^2$. The middle account speed of movement of air in this channel $u_0=3$ m/s, Reynolds's number $Re_0=20000$ and $\lambda_0=0,054$. Substituting values of the sizes entering into the formula (7) we will find that $\omega \geq 1.3$ 1/s.

Thus, 12 rpm is enough for the natural turbine ventilation, while at speed of a wind 7 m/s for the turbine chosen by us $\omega = 7.875$ 1/s or 75 rpm. Let's notice, at drill machine speeds of a wind of 12-15 km/s the wind turbine will have 129-161 rpm. Thus, the work of centrifugal forces suffices for the organization of natural

ventilation in the turbine, even if for strengthening of rigidity of mach and there is an armature of working blades in their cavities.

On figure 3 shows a schematic construction diagram allows to organize the thermal protection of the rotating turbine type H - the rotor.

Vertical position of wind turbine is provided with the central rack (1) which bottom end leans against the strong base. For giving of strictly vertical position and stability of all system it is used the tripartite extensions-cables attached by the top end of a rack (1) and three equidistant from each other to strong hooks, located on level of a surface of the earth so that cables did not disturb to rotation of the turbine. Apparently from figure 3 design wind turbine is constructed so that the warmed-up ventilating air did not wash away lubricant oils at bearings, leading to their dry friction.

Rack (1) and a shaft of rotation of the turbine (2) are divided by bearings (3). The shaft of rotation (2) turbines represents the flowing ring channel (9) which constancy of section is provided with hairpins (5). External the cylindrical form the surface (4) is blown by a wind. The warmed-up air rises on the ring channel (9) and then (7) rotating turbines approach on cavities of moves (6) to working blades, and through apertures on the ends of blades it is thrown out outside. There is a pulley (8) for connection with the electrogenerator.

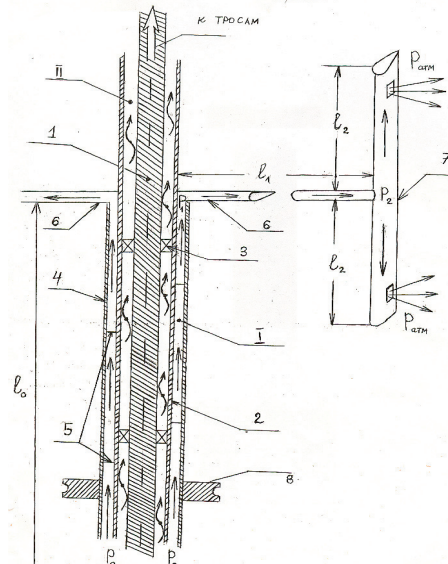

Figure 3 - Basic construction diagram of the turbine type H - Rotor

Let's notice also that through a wall (2) shaft of rotation the part of heat from the channel (9) will be transferred in (10) and formed ascending weak convective of air (on fig. 3 it is shown by a wavy arrow), providing thermal protection of the top part of the central rack (1).

References

- 1 Darrieus F.M. Turbine Having in Rotation Transverse to the Flow of Current // US Patent 1. - 834/018 Doc. B. - 1931.
- 2 Schlichting G. Boundary layer theory. // Moscow: Nauka. - 1974.
- 3 Yershina A.K., Manatbayev R.K. // Determination of hydraulic resistance of a symmetric airfoil NASA – 0021 // Bulletin of KNU, a series of mathematics, mechanics, computer science. – 2006. - № 4. - P. 56-58.