

IRSTI 44.35.31

\*G. Kazakbay, D. Turalina

Faculty of Mechanics and Mathematics,  
al-Farabi Kazakh National University, Almaty, Kazakhstan,  
\*e-mail: ggauharkb@gmail.com

### **Research with purpose of defining the lift and drag forces acting on hydro turbine blade with changing attack angle of flow**

**Abstract.** In this paper the results of the research conducted to determine the effective version of hydro wheel blades of direct flow hydro turbine are presented. The aim of the research is to determine the optimal configurations of hydro turbine blades to improve the energy efficiency of the turbine. As a result of the study, a mathematical model of a hydro turbine was developed in the interactive COMSOL Multiphysics. Research was performed in the COMSOL Multiphysics application program with using Reynolds Averaged Navier Stokes method to Navier-Stokes equation for incompressible fluid. Direction of flow to blades with changing attack angle along blades was investigated. The change in velocity and pressure distribution of water through hydro turbine blades was considered. The optimal location of the blades was determined. Defined lift and drag forces acting along the blade. Based on the results of the research, it was determined the optimal configurations of the hydro wheel blades with high energy efficiency.

**Key words.** Hydro turbine, blade, COMSOL Multiphysics, lift force, drag force.

#### **Introduction**

Scientific research work is related to improving the energy efficiency of hydro turbine by changing the stream flow to hydro wheel. Hydropower plants use energy of water flow as the source of energy. Hydro turbine is the hydro engine that turn coming flow energy to mechanical energy.

Today, the whole world pays great attention to water flow energy as the effective source of energy. Investigated hydro turbine for small hydroelectric power station does not require a dam. Instead, it works in scheme as a part of the water given to head tube, after flowing through hydro turbine again dumped into the river. This direct flow hydro turbine size is small, so to construct it need less material accordingly it cost cheaper.

It is significant to correct choosing of the structure of the turbine, the size and location of the blades, the parameters of the guide vane, the head of water, the structure of the hydro wheels when installing a hydro turbine on a water stream to generating sufficient energy and effective working. Scientific research working is aimed to improving low head hydro turbine ef-

iciency by changing the stream flow to hydro wheel. Research the optimal version of the attack angle of guide vane and hydro wheel blades with the purpose of improving efficiency of hydro turbine. Investigated low head hydro turbine can be used in the small and medium rivers of the Central Asian countries and Kazakhstan. This low head hydro turbine for small hydroelectric power station is for using for seasonal agriculture to farmers and for using in small settlements and remote villages [1, 2].

#### **Computational experiment**

The method of research is a numerical experiment. A theoretical study was carried out, a mathematical model of a hydro turbine blade was performed in the COMSOL Multiphysics application package. The COMSOL Multiphysics examines the distribution of velocity and pressure of water along the turbine blades [3]. Showed external construction of 3D model of hydro turbine in the interactive of COMSOL Multiphysics application package in Figure 1. Internal construction of the hydro turbine is showed in Figure 2.

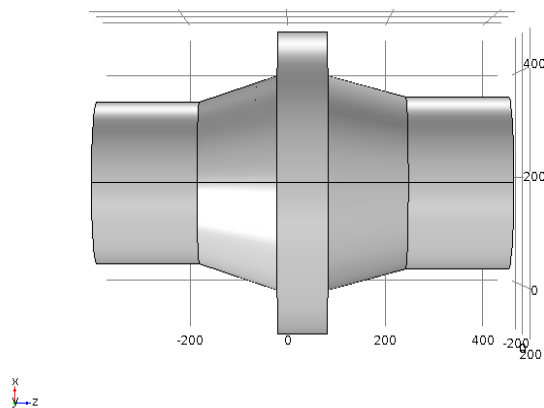

**Figure 1** – Model of hydro turbine

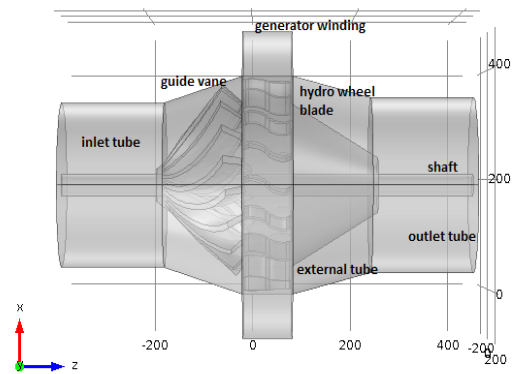
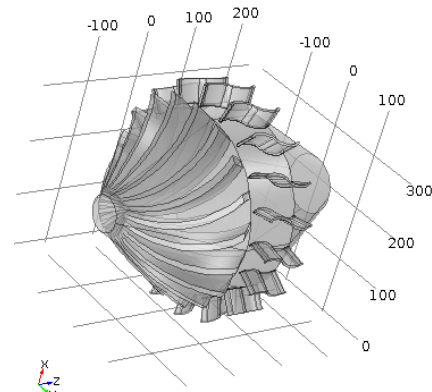
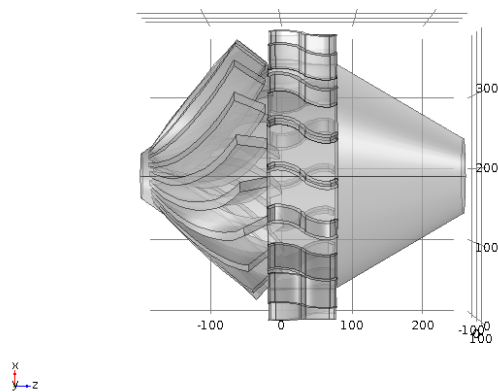

**Figure 2** – Internal construction of the hydro turbine

Water enter through inlet tube, guide vane, rotating hydro wheel and pass through turbine then exit through outlet tube.

Guide vane and hydro wheel of the hydro turbine is showed in Figure 3. Front part as cone, blade located at as cylinder part.

To take as more energy is needed to turn as more the hydro wheel. Therefore, there is a guide vane with the aim to regulate impact and direction of water flow to the hydro wheel blades. When water flow through hydro turbine passing through guide vane and hit blades with pressure, and they rotate [4].



**Figure 3** – Guide vane and hydro wheel

The energy efficiency of the hydro turbine is influenced by the number, shape, location, and attack angle of the guide vane and blades [5]. Therefore, the results of the research of the attack angle of the hydro wheel blades are presented. Attack angle is the angle between coming flow direction and chord line of the blade. Research was conducted with the purpose of improving the energy efficiency of hydro turbine.

Numerical calculation was performed by COMSOL Multiphysics application package. The results were obtained by changing the attack

angle of blades of hydro wheel for shaping the two dimensions. Three different angles were obtained to show the improving in energy efficiency and to compare. Analyzed the distribution of velocity and pressure of water flow in COMSOL Multiphysics application package for 10 seconds, suggesting that the velocity at 1 m/sec [6].

Distribution of water flow velocity and pressure was calculated with using Reynolds Averaged Navier Stokes (RANS) method to Navier-Stokes equation for incompressible fluid.

For incompressible fluid Navier-Stokes equations consists of motion and continuity equation [7]:

$$\rho \frac{\partial u}{\partial t} + \rho(u \cdot \nabla)u = \nabla \cdot [-pI + (\mu + \mu_r)(\nabla u + (\nabla u)^T)] + F \quad (1)$$

$$\rho \nabla \cdot (u) = 0$$

Boundary conditions of the chosen blades in two dimension is showed in Figure 4.

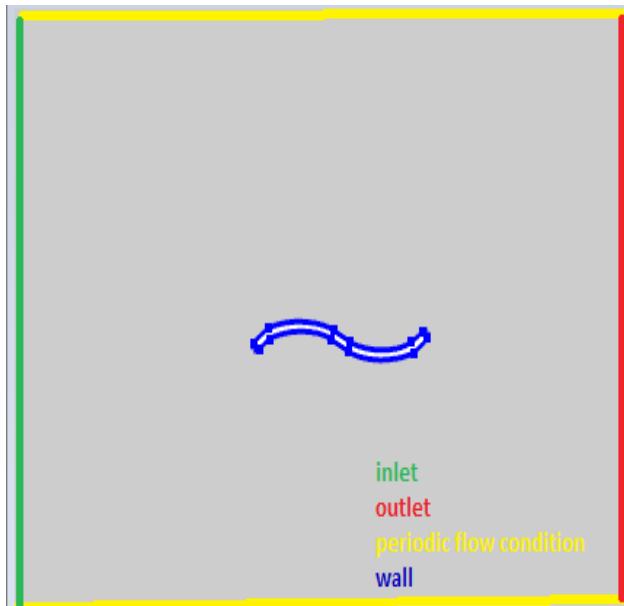

Figure 4 – Boundary conditions

Inlet:

$$U \cdot \cos(\alpha \cdot \pi / 180), U \cdot \sin(\alpha \cdot \pi / 180)$$

Outlet: Neumann boundary condition

Wall: No slip

Periodic flow condition:

$$u_{source} = u_{dest}, p_{source} = p_{dest}$$

Periodic Flow Condition is used that take account that chosen blade is affected by the changes in the water velocity flowing along the under and upper blades.

Mesh allocation of model is showed in Figure 5.

### Defining optimal attack angle of the blades

There are two ways to change the attack angle of the model. It is possible to turn the blade itself or to fixed blade but change the flow direction at the inlet. Second way is more simple to adjust the velocity

field at the inlet boundary condition and there is no need to remesh the model for every attack angle.

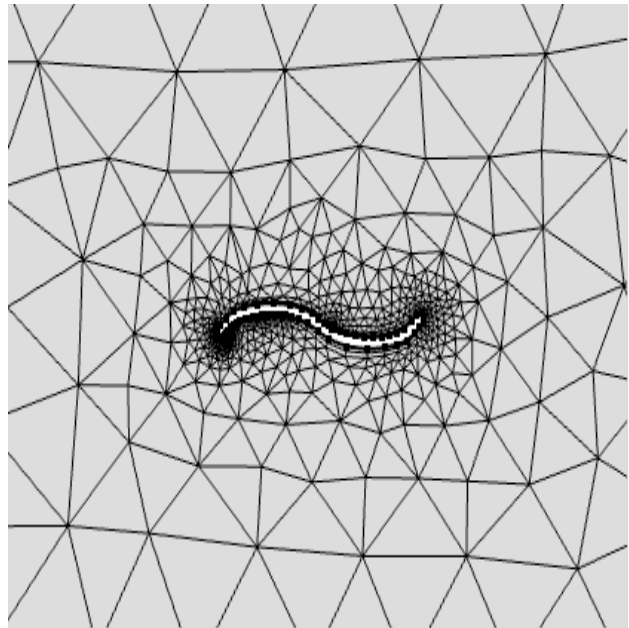

Figure 5 – Mesh allocation

Scheme of attack angle of the hydro wheel blade  $\alpha$  illustrated in Figure 6.

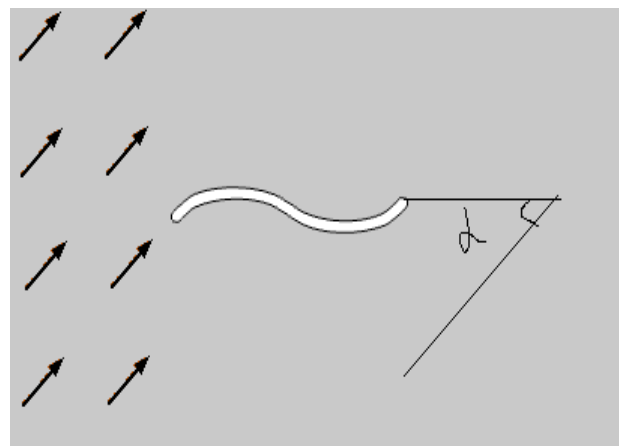

Figure 6 – Attack angle

Arrow is showed water flow direction. There  $\alpha$  means attack angle. Attack angle is the angle between coming flow direction and chord line of the blade. The initial velocity of the water flow are determined as  $U \cdot \cos(\alpha \cdot \pi / 180)$  in x direction and as  $U \cdot \sin(\alpha \cdot \pi / 180)$  in y directon. Here  $U = 1$  m/s. Considered three various location of blades with changing attack angle. Values of attack angle  $\alpha$  are  $40^\circ, 45^\circ, 60^\circ$ .

Results of velocity changing and pressure distribution along blade in 10 second, changing attack angle to 40° demonstrated in Figure 7.

Changing of colour from blue to red showed increasing of velocity and pressure. Arrow is showed water flow direction. In this case the maximum value

of velocity reached to 1.32 m/s and pressure 565 Pa. Pressure increase in the bottom side of the blade as a result of the appearing lift force.

Results of velocity changing and pressure distribution along blade in 10 second, changing attack angle to 45° demonstrated in Figure 8.

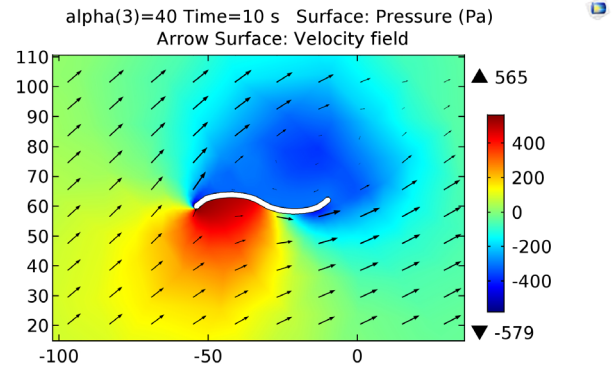
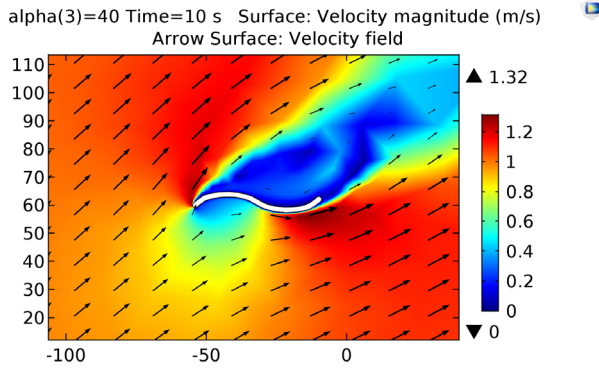

Figure 7 – Blade’s attack angle 40°

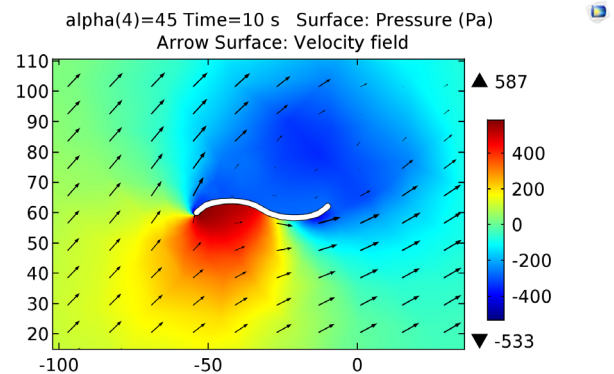
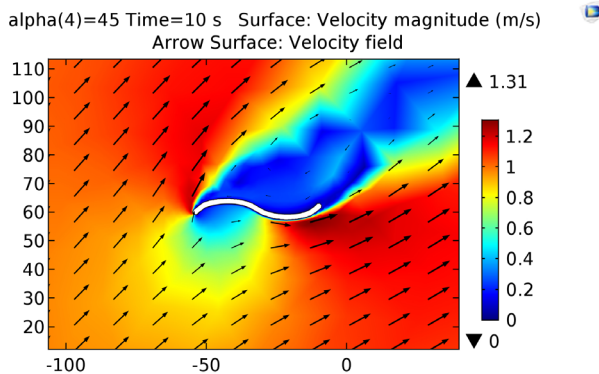

Figure 8 – Blade’s attack angle 45°

There maximum value of velocity reached to 1.31 m/s and maximum value of pressure reached 587 Pa. Comparing with previous results observed the much more efficiently. So we see that attack angle has affect.

Results of velocity changing and pressure distribution along blade in 10 second, changing attack angle to 60° demonstrated in Figure 9.

There maximum value of velocity reached to 1.26 m/s and pressure reached to 595 Pa. Changing attack angle affected to previous results.

Results of numerical experiment by COMSOL Multiphysics changing of velocity and pressure distribution of flow with changing attack angle of the blades are showed in Table 1.

Table 1 – Velocity and pressure changing with changing attack angle

Name	Attack angle of blades, °	Maximum value of velocity of flow, m/s	Maximum value of pressure of flow, Pa
1	40	1.32	565
2	45	1.31	587
3	60	1.26	595

In version when blade’s attack angle 40° maximum value of velocity is reached. Maximum value of pressure is reached when blade’s attack angle 60°.

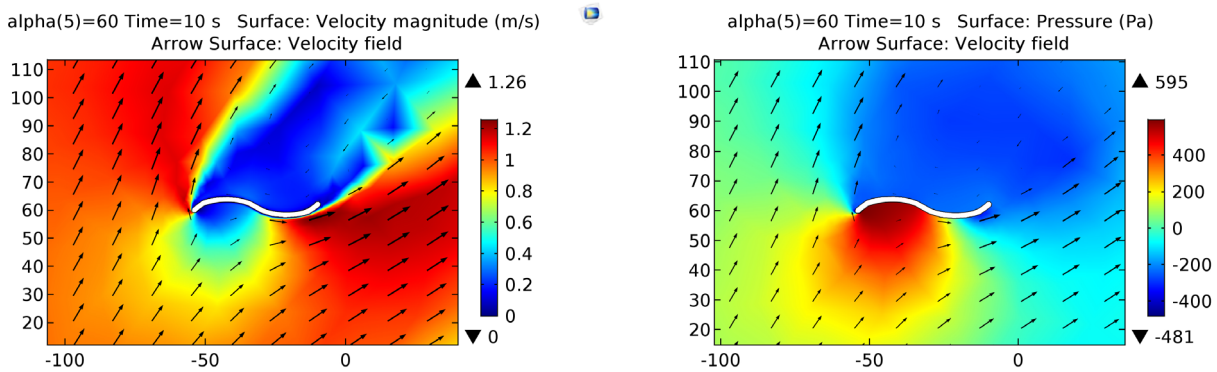

Figure 9 – Blade’s attack angle 60°

**Defining lift and drag forces**

When fluid flow passes a body, it exerts a force on the surface. The force component that perpendicular to the flow direction is called lift force  $F_L$ . The force component that parallel to the flow direction is called drag force  $F_D$  [8]. Scheme of the lift and drag forces acting on blade is illustrated in Figure 10.

lar to the flow direction is called lift force  $F_L$ . The force component that parallel to the flow direction is called drag force  $F_D$  [8]. Scheme of the lift and drag forces acting on blade is illustrated in Figure 10.

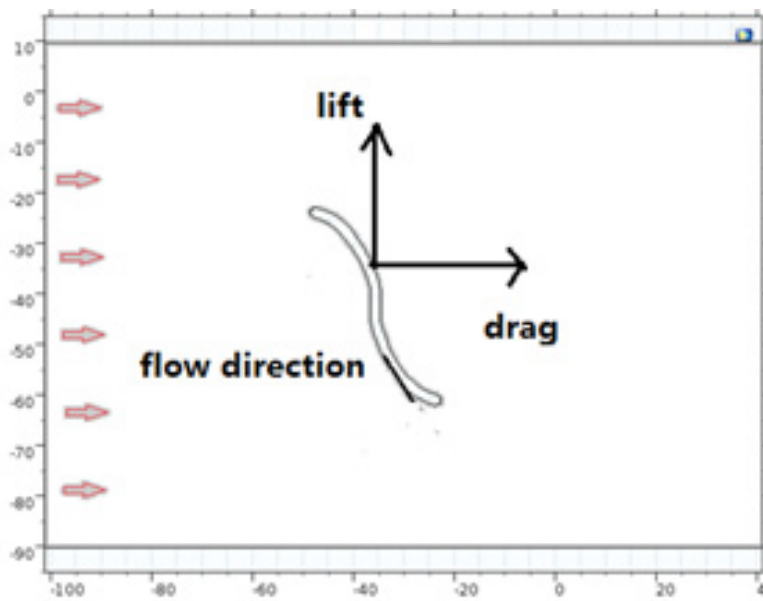

Figure 10 – Lift and drag force

There are two distinct contributors to lift and drag forces – pressure force and viscous force. The pressure force is the force appearing due to the pressure difference across the surface. The viscous force is the force deriving from friction that acts in the opposite direction of the flow [9].

Lift and drag forces at different angle attack of the blade at last time showed in Figure 11. Was

chosen as various angle attack as 0°, 15°, 40°, 45°, 60°, 90° [10].

Last time is tenth second. Drag force increasing from 0 angle degree to 45 angle degree, then started to decreasing. Lift force increasing from 0 to 45 angle degree, then decreasing. So at 45 angle degree take maximum value of lift and drag force. At 60 angle degree take minimum value of drag force.



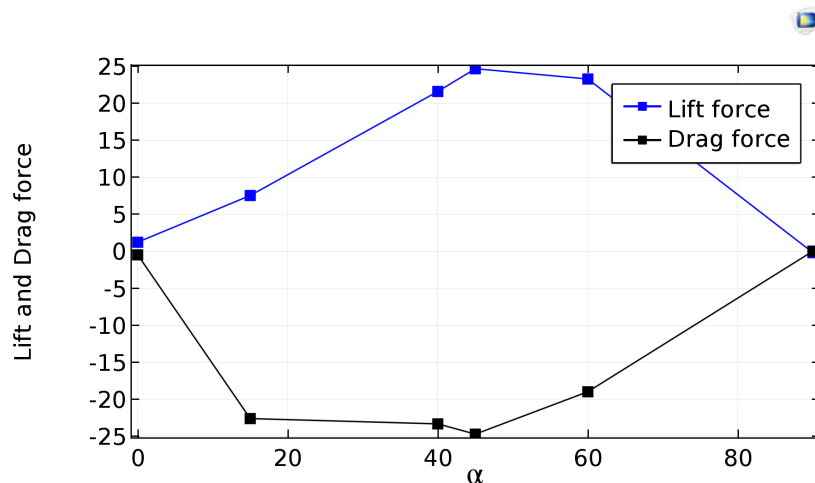

Figure 11 – Lift and drag force at last time

### Conclusion

The effective version of hydro wheel blades of direct flow hydro turbine was determined. Research with the aim of improving efficiency of low head hydro turbine was performed. Three various location of the blades with changing attack angle investigated in the COMSOL Multiphysics application package. Based on the results of the research, it was determined the optimal configurations of the hydro wheel blades of the hydro turbine with effective efficiency. As optimal configuration was taken hydro wheel blade with attack angle 60° angle degree, where maximum value of velocity reached to 1.26 m/s and maximum value of pressure reached to 595 Pa. Defined lift and drag forces at different attack angle. Maximum value of lift force and minimum value of drag force defined at blade attack angle at 60 angle degree.

### References

1. Koshumbayev M., Yerzhan A. "The innovative design of free-flow hydraulic turbine small hpp." *Materials of 2<sup>nd</sup> International conference on innovative trends in multidisciplinary academic research*. Turkey. Istanbul, 2015.
2. Turalina D.E., Bossinov D.Zh. "Theoretical and experimental investigations to define optimal parameters of straight-flow turbine for non-dam hydro power station." *KazNU Bulletin (Mathematics, Mechanics, Computer Science Series)* 84 (2015): 124-131.
3. COMSOL Multiphysics User's Guide. 2012: P. 1292.
4. Stesina S.P. *Gidravlika, gidromashini i gidropnevmoprivod: ycheb. posobie dlya vyzov*. M.: Akademiya, 2007: 336 p.
5. Bashta T.M., Rydnev S.S., Nekrasov B.B. *Gidravlika, gidromashini i gidroprivodi: Ycheb. dlya vyzov*. M.: Alyans, 2010. 423 p.
6. Kazakbay G.B., Turalina D.E. "Research of the influence of lift force in accordance with the attack angle of water flow on the hydro wheel blades." *V International Farabi readings International scientific conference of students and young scientist*. Kazakhstan. Almaty, 2018.
7. Loytsyanskii L.G. *Mechanics of liquids and gases*. Oxford: Pergamon Press, 1966. 803 p.
8. Nakayama Y. *Introduction to Fluid Mechanics*. Oxford: Butterworth-Heinemann, 2000. 322 p.
9. Al-Shemmeri T.T. *Engineering Fluid Mechanics // The ebook company: Bookboon*. –2012. P. 147.
10. Lyu, Peter. "How Do I Compute Lift and Drag?" *COMSOL Blog*. <http://www.comsol.com/blogs/how-do-i-compute-lift-and-drag>.